



LOT 14
Floor area: 106.2m²
Site area: 222m²







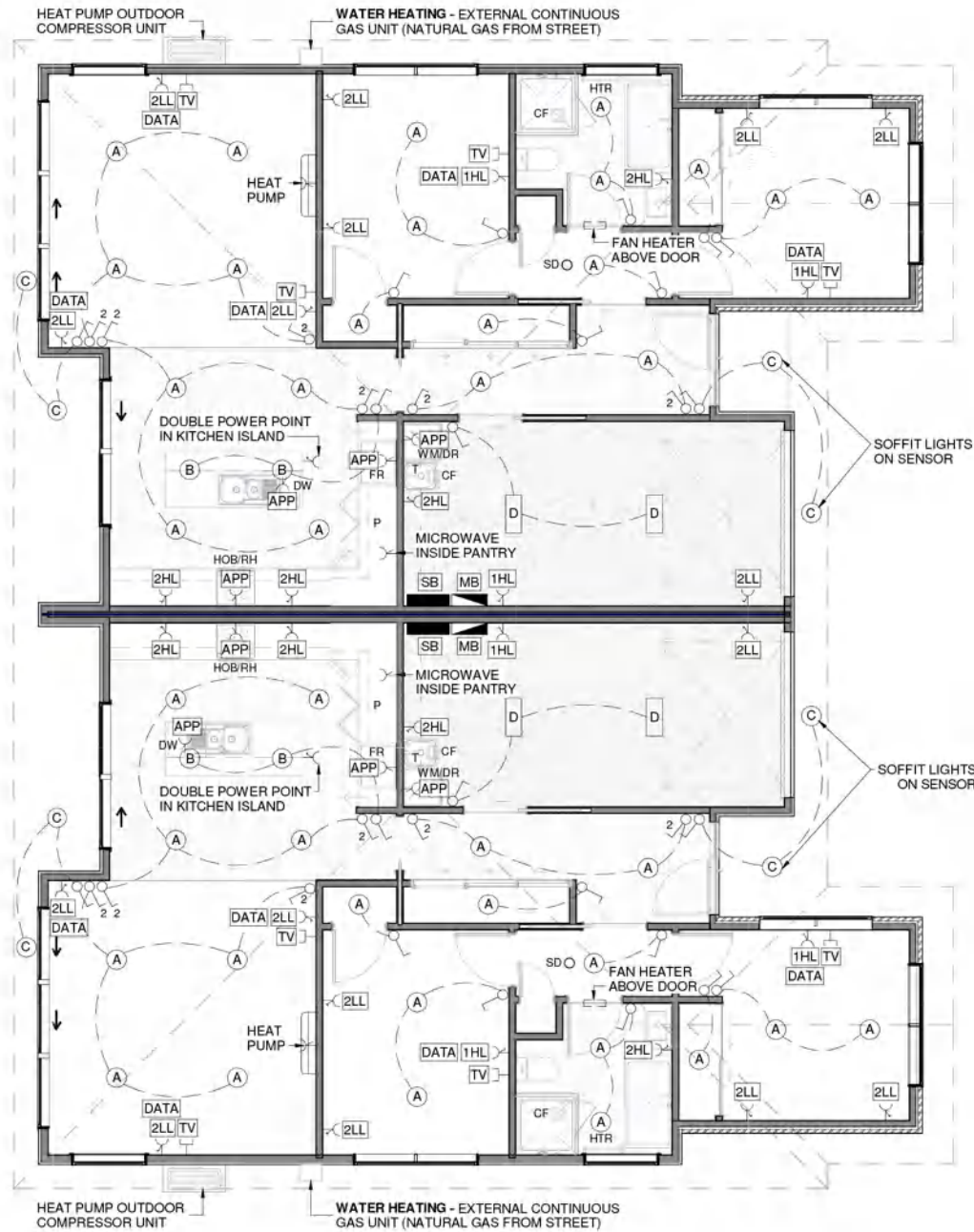





LOT 15
Floor area: 106.2m²
Site area: 219m²







Primary wall cladding: Brick veneer (stack bond)
Feature wall cladding: Abodo horizontal rusticated weatherboards
Roof cladding: Corrugated profile



LEGEND - ELECTRICAL

-  DOUBLE POWER SOCKET - LOW LEVEL (LL) 440 AFFL
-  DOUBLE POWER SOCKET - HIGH LEVEL (HL) 1200 AFFL
-  SINGLE POWER SOCKET - HIGH LEVEL (HL) 1200 AFFL
-  APPLIANCE POWER SOCKET
-  TV AERIAL OUTLETS
-  DATA / TELEPHONE OUTLETS
-  LIGHT SWITCH - 1 WAY
-  LIGHT SWITCH - 2 WAY
-  SMOKE DETECTOR - 1/ HARD WIRED DETECTOR WITHIN 3 METERS OF ALL BEDROOM DOORS
-  CEILING EXTRACTOR FAN - ON BATHROOM AND LAUNDRY
*WEISS FV110 IN-LINE EXTRACTOR FAN ON TIMER SWITCH DUCTED TO SOFFIT WITH 150mm DIA FLEXIBLE DUCTING
-  SWITCH BOARD / DATA HUB
*FIBRE FROM DATA HUB TO OUTSIDE CONNECTION POINT
-  METER BOX
*SMART METER (DOESN'T NEED TO BE OUTSIDE)

LEGEND - LIGHTING

-  RECESSED LED DOWNLIGHT - TYPE IC RATED
* INSULATION CAN BE INSTALLED OVER THE TOP OF THE RECESSED LUMINAIRE
-  PENDANT LED LIGHTS - REFER TO CLIENT SPEC. FOR SELECTIONS
-  EXTERIOR LIGHT SOFFIT MOUNTED
-  LED BATTEN LIGHTS FOR GARAGE

